



Unit 5L, Delta Drive, Tewkesbury, Glos. GL20 8HB. United Kingdom.

## Tensioner meters.

Model No.	Range	Resolution	Tension Units
<b>CX-1000</b>	23 -454 KG	2.26 KG	N, KG or Ib
<b>CX-2000</b>	45 - 907 KG	4.5 KG	N, KG or Ib

Large, easy to read backlit, graphic display with adjustable backlighting and contrast.

- **A - Analog Output Option**

Analog Output Option for both speed and tension values. 0-5 VDC or 4 -20 mA with software-definable ending sequences. Provided with 10' cable. Data outputted at 40Hz.

- **E - RS-232 Serial Output Option**

Provided with 10' cable to interface with your receiving device. Select data sampling rate from 1, 2 or 5 Hz.

- **D - Data Logging Option**

Capture and view data within a user-defined time window. Select the time window; then select the sampling rate (from 1-100 Hz). After capturing the data, review the data on the instrument's display or upload it using the 10' serial interface cable.

Order code:- [Model number] + [options] - e.g. CX-1000-A-E

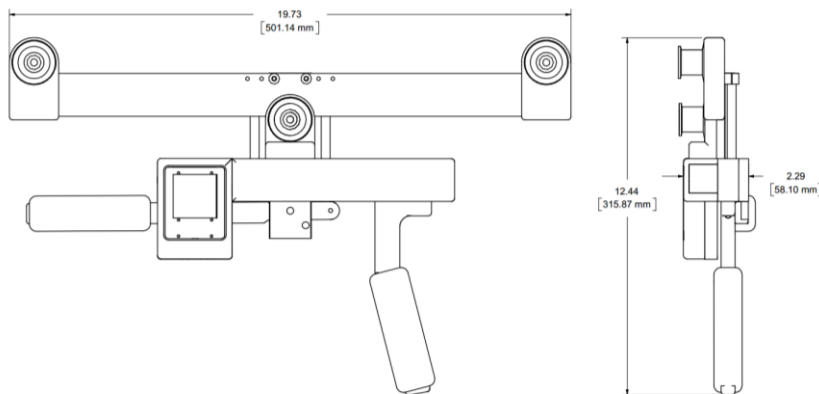

We aim to be much more than a machinery supplier. Our team has a vast range of winding experience and is able to offer help and advice on all aspects of coil winding, from tooling design to machine choice and set-up.

**~ Coil winding solutions you can rely on ~**



Working with local partners in the following countries;

Austria, Czech Republic, Germany, Hungary, Poland, Portugal, Romania, Slovakia, Slovenia, Spain, Sweden.