



Unit 5L, Delta Drive, Tewkesbury, Glos. GL20 8HB. United Kingdom.

## Tensioner meters.

Model No.	Range	Resolution	Tension Units
LX-250	2.5 -113 KG	0.22 KG	N, KG or lb
LX-500	11 - 225 KG	0.45 KG	N, KG or lb

Large, easy to read backlit, graphic display with adjustable backlighting and contrast.

### A - Analog Output Option

Analog Output Option for both speed and tension values. 0-5 VDC or 4 -20 mA with software-definable ending sequences. Provided with 10' cable. Data outputted at 40Hz.

### E - RS-232 Serial Output Option

Provided with 10' cable to interface with your receiving device. Select data sampling rate from 1, 2 or 5 Hz.

Order code:- [Model number] + [options]

e.g. Lx1-250-A-E

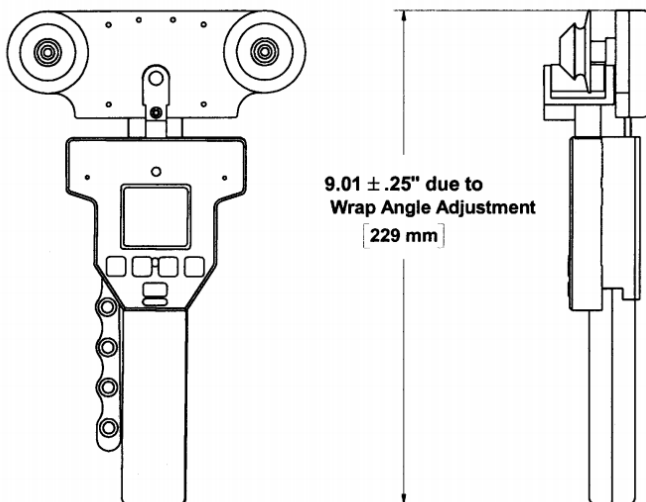
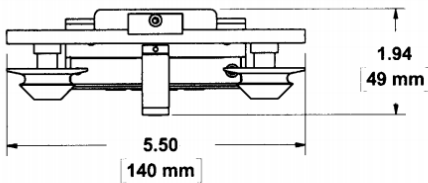

We aim to be much more than a machinery supplier. Our team has a vast range of winding experience and is able to offer help and advice on all aspects of coil winding, from tooling design to machine choice and set-up.

## ~ Coil winding solutions you can rely on ~



Working with local partners in the following countries;

Austria, Czech Republic, Germany, Hungary, Poland, Portugal, Romania, Slovakia, Slovenia, Spain, Sweden.