

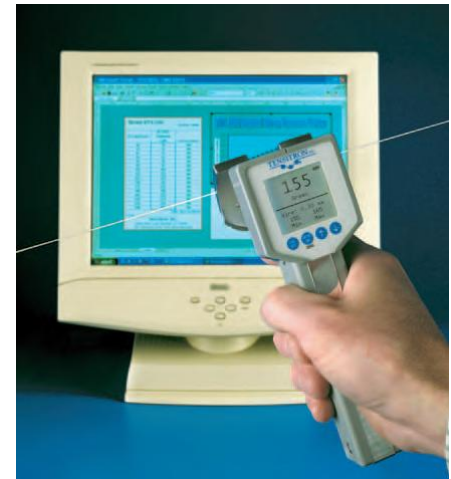

Unit 5L, Delta Drive, Tewkesbury, Glos. GL20 8HB. United Kingdom.

## Tensioner meters.

Model No.	Range	Resolution	Tension Units
TX-125	0-125g	0.1 to 1g	cN, grams or lb
TX-1000	10-1000g	1 to 5g	N, grams or lb
TX-5000	50-5000g	5 to 10g	N, grams or lb
LX-250	2.5 -113 KG	0.22 KG	N, KG or lb
LX-500	11 - 225 KG	0.45 KG	N, KG or lb



Large, easy to read backlit, graphic display with adjustable backlighting and contrast.

### S - Speed and Length Option

Indicate real-time speed in FPM, or MPM. Maximum measurable speed is 9,999 FPM or 9,999 meters per minute, however line speeds in excess of 2,000 FPM are generally unsafe for hand-held applications. Read length of part run in feet or meters. Maximum length measuring up to 9,999 meters or feet.

### A - Analog Output Option

Analog Output Option for both speed and tension values. 0-5 VDC or 4 - 20 mA with software-definable ending sequences. Provided with 10' cable. Data outputted at 40Hz.

### E - RS-232 Serial Output Option

Provided with 10' cable to interface with your receiving device. Select data sampling rate from 1, 2 or 5 Hz.

### D - Data Logging Option

Capture and view data within a user-defined time window. Select the time window; then select the sampling rate (from 1-100 Hz). After capturing the data, review the data on the instrument's display or upload it using the 10' serial interface cable.



1	175
2	180
3	185
4	215
5	210
6	200
7	175

Order code:- [Model number] + [options]

e.g. tx-1000-S-D

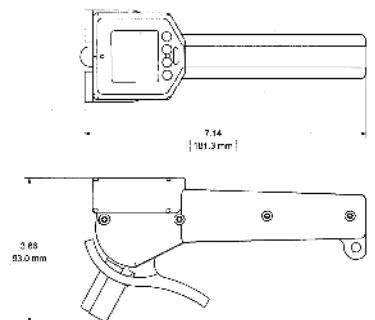
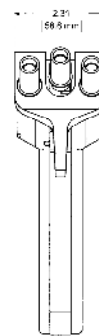

We aim to be much more than a machinery supplier. Our team has a vast range of winding experience and is able to offer help and advice on all aspects of coil winding, from tooling design to machine choice and set-up.

## ~ Coil winding solutions you can rely on ~



Working with local partners in the following countries;

Austria, Czech Republic, Germany, Hungary, Poland, Portugal, Romania, Slovakia, Slovenia, Spain, Sweden.