



[www.coilwindingmachines.eu](http://www.coilwindingmachines.eu)

Tel: +44(0)1684 273164 Fax: +44(0)1684 273171 Email: [enquiry@ingridwest.co.uk](mailto:enquiry@ingridwest.co.uk) by Ingrid West Machinery Ltd

Unit 5L, Delta Drive, Tewkesbury, Glos. GL20 8HB. United Kingdom.

## FOIL WINDING MACHINE SERIES

One of the latest developments at Erasan Zinzo is the range of foil winding equipment, with high-tech control features, improving quality of winding and reducing maintenance to a minimum.

Shown below are some of the machines already delivered along with concept drawings showing a basic machine layout.

There are various configurations possible, up to 1500mm width. This allows winding of primaries easily and with very short production cycle times.



By using very large powerful "Parker motor" with integrated gear box drive systems, a strong robust machine construction is achieved

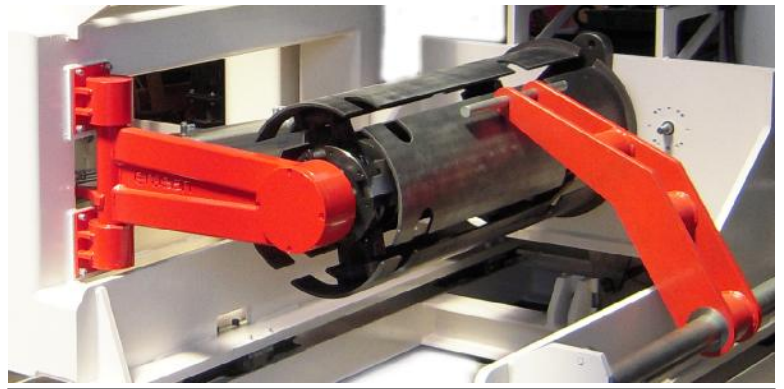

Expanding mandrels are made in house, to suit the exact requirement of the machine and product to be made.

We aim to be much more than a machinery supplier. Our team has a vast range of winding experience and is able to offer help and advice on all aspects of coil winding, from tooling design to machine choice and set-up.

**~ Coil winding solutions you can rely on ~**



Working with local partners in the following countries;

Austria, Czech Republic, Germany, Hungary, Poland, Portugal, Romania, Slovakia, Slovenia, Spain, Sweden.

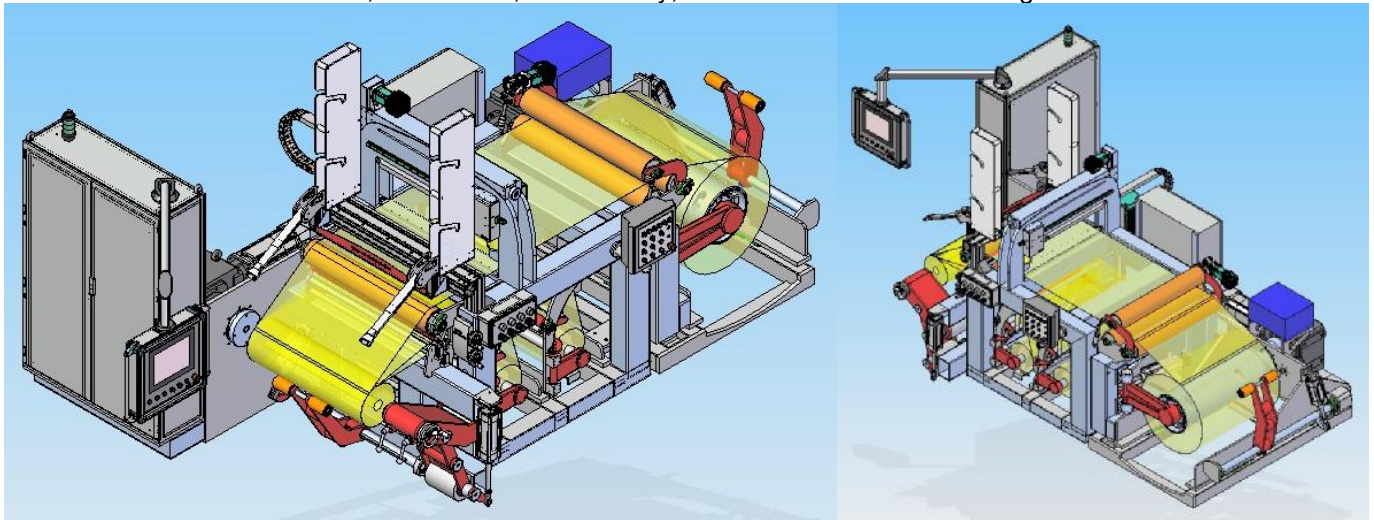

Various stages / process of automation can be added to the function of the machine according to your requirements. Shown here is a cold pressure welding station, used for fixing the terminal leads "in-line" during the winding.

## Please contact your local partner for more information

### TECHNICAL CHARACTERISTICS.

Various configurations of machine available depending on your application requirements,

For example:-

1 foil, 1 insulator // 1 foil, 2 insulators // 2 foils, 2 insulators.

Max foil width.....

600, 900 up to 1500 mm

Guider precision .....

built in sensor detecting the foil edge creates a continuous feedback loop to ensure precise turn on turn foil layering

Type of programming.....

CNC- industrial PC

DELIVERY TIME.....

6-9 months from order confirmation.

(Please confirm at time of order)

We aim to be much more than a machinery supplier. Our team has a vast range of winding experience and is able to offer help and advice on all aspects of coil winding, from tooling design to machine choice and set-up.

## ~ Coil winding solutions you can rely on ~



Working with local partners in the following countries;

Austria, Czech Republic, Germany, Hungary, Poland, Portugal, Romania, Slovakia, Slovenia, Spain, Sweden.